

Understand Wireless Data Sheet Specifications - Part 1

This tutorial introduces and defines RF terms used in data sheets for mixers, amplifiers and oscillators. Terms described include gain, conversion gain, phase noise, third order intercept, P1dB, insertion loss, output power, tuning gain and tuning range. Graphics, images are provided to illustrate key concepts.

This tutorial explains some common specifications found in wireless IC data sheets. These specifications are for amplifiers, mixers, and oscillators. The specifications for amplifiers and mixers are the same, with few exceptions. Voltage-controlled oscillators (VCO) have a unique set of specifications.

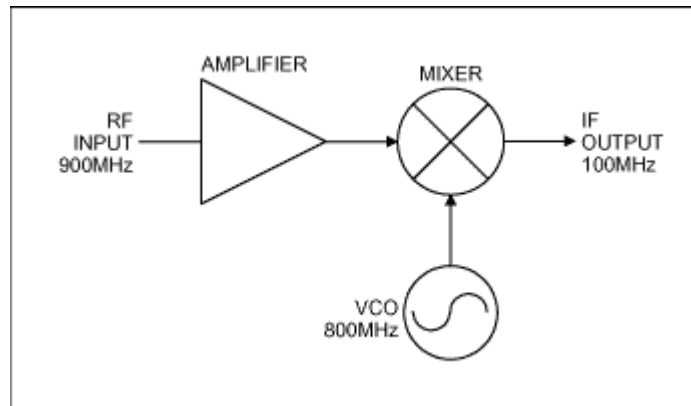

Figure 1. Amplifier, mixer, and VCO form a simple wireless receiver.

Common Amplifier and Mixer Specifications

Gain is the voltage or power gain of a wireless building block (i.e. amplifier or mixer). The gain specification is almost always given in dB in the data sheet. The three terms: gain, voltage gain, and power gain are often interchangeable. This is because the gain value is the same for both voltage and power gain in dB when the input and output impedance are the same. For example, 20dB gain is equivalent to a voltage gain by a factor of 10 V/V. A voltage gain of 10V/V is also equivalent to power gain of 100 W/W, which is also 20dB. Voltage gain and power gain in the linear scale are different, but in dB they are the same, thus allowing the terms to interchange without confusion.

Conversion Gain specification is for mixer or frequency translation devices. It is called conversion gain because the input and output frequencies are different. The input signal is converted to a lower or higher frequency by the mixing action.

Insertion Loss or Attenuation is a gain specification except output level is typically decreased relative to the input. That is, the output signal amplitude is less than the input.

Output power is the amount of RF power available for driving a load, typically 50Ω. It is usually expressed in dBm. dBm is the number of milliwatts in dB. For example, 250mW is $10 \cdot \log_{10}(250) = +24\text{dBm}$.

Here are a few examples of power in dBm, assuming the impedance is 50Ω:

$$\begin{aligned}
 +30\text{dBm} &= 1\text{W} = 7.1\text{V}_{\text{RMS}} \\
 0\text{dBm} &= 1\text{mW} = 0.225\text{V}_{\text{RMS}} \\
 -100\text{dBm} &= 0.1\text{pW} = 2.25\text{uV}_{\text{RMS}}
 \end{aligned}$$

1dB Compression Point (P1dB) is a figure-of-merit for output power. Higher compression point means higher output power. P1dB is at an input (or output) power such that the gain is lowered by one dB when compared to the gain at very low power. Refer to Figure 2, gain vs. input power plot. Note how the gain is lowered as the input power is increased. This is because the output saturates at its maximum and no further increase in power is possible. The 1dB compression point can be specified at the input or output. For example, if the output P1dB specification is +20dBm, the output power for this component is about +20dBm. Reducing the output power from P1dB will reduce distortion.

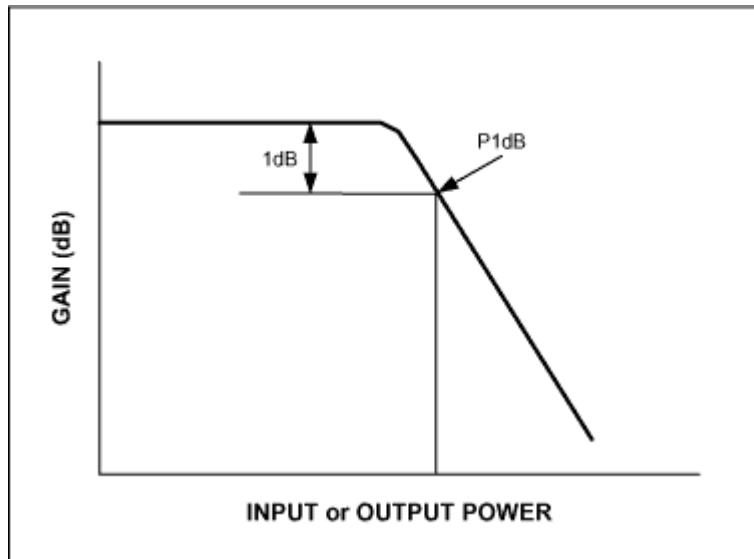

Figure 2. Gain vs. input power plot of a component (amplifier or mixer). The gain is lowered at high output power because the output is saturated.

Third-Order Intercept Point (IP3) is a figure-of-merit for linearity or distortion. Higher IP3 means better linearity and less distortion. IP3 is commonly tested with two input tones. Figure 3 illustrates the two-tone IP3 test in the frequency domain. The inputs to the amplifier are two sinewaves (fundamental), one at 900MHz and the other at 901MHz in the example shown here. At the output of the amplifier are the two desired signals. Because the amplifier is not perfectly linear, it also produces two third-order intermodulation (IM3) products. IM3 is often given in dBm. The IM3 distortion products are shown here very close in frequency to the desired signals and they cannot be removed easily by filtering. To reduce third order distortion products, the IP3 specification must be increased.

The third-order intermodulation products are the result of inter-mixing (or modulating) the two-tone inputs by the non-linearities in the amplifier or mixer. The two IM3 products are:

$$\begin{aligned}
 f_{\text{IM3}_1} &= 2 \cdot f_1 - f_2, & \text{i.e. } 900 \cdot 2 - 901 &= 899\text{MHz} \\
 f_{\text{IM3}_2} &= 2 \cdot f_2 - f_1, & \text{i.e. } 901 \cdot 2 - 900 &= 902\text{MHz}
 \end{aligned}$$

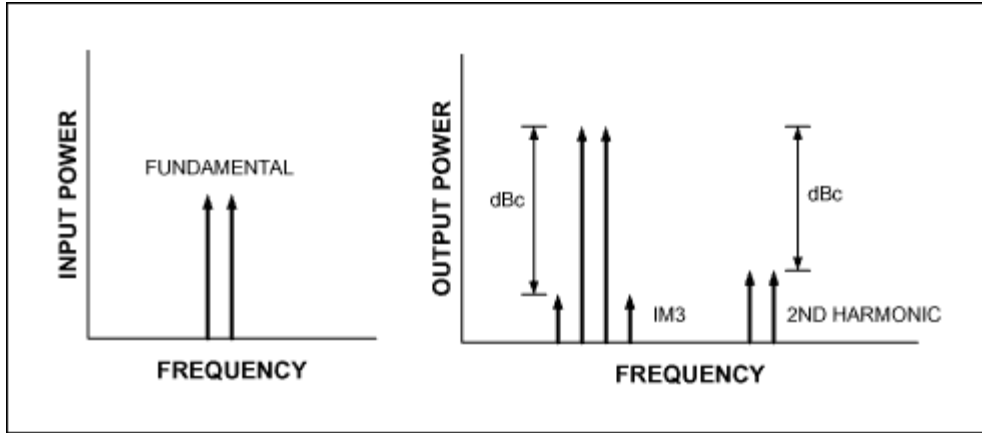

Figure 3. Two-tone IP3 test. (Left) Two input tones at the input. (Right) The output contains the two amplified tones, IM3 products, and harmonic distortions.

In mathematical terms, IP3 is a theoretical input power point at which the fundamental and third-order distortion output lines are intercepted (see Figure 4). Line A is the output power vs. input power curve for the fundamental (desired) signal, and line B is third-order distortion output power vs. input power curve. The slope for line B is three times as steep (in dB) and theoretically intersects line A. The intercept point is the third-order intercept point. The hypothetical input power at this point is the input IP3 and the output power is the output IP3.

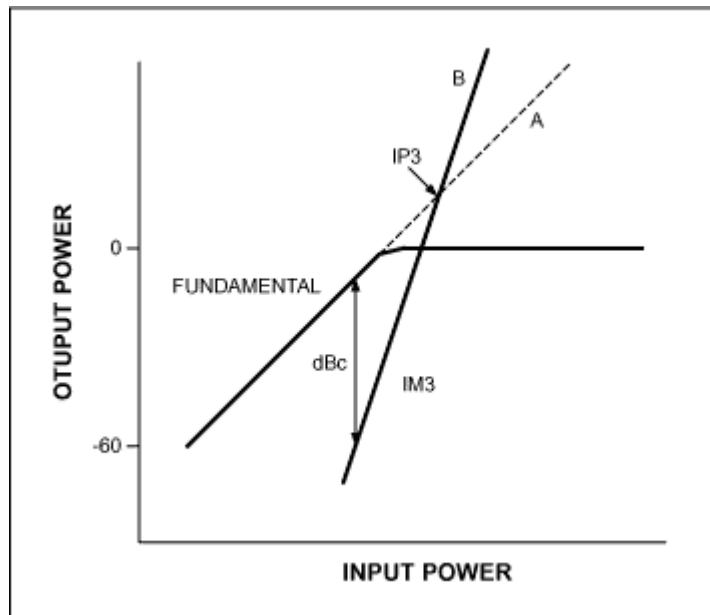

Figure 4. Definition of IP3. The point where line A and line B are intercept is the hypothetical IP3.

Harmonic Distortion is another distortion specification. It specifies the distortion products created at integer multiples of the fundamental frequency (Figure 3). For example, a second harmonic distortion specified as -60dBc means the distortion output amplitude at twice the fundamental frequency is 60dB below the fundamental. Thus dBc is the number of dB below the fundamental (dBc traditionally means dB below the carrier). The harmonic distortion specification is critical in broadband applications such as cable TV, but less important in narrowband applications such as handsets because the distortion products can be easily filtered out, since they are separated by a large frequency difference.

Noise Factor is a figure-of-merit for noise produced by amplifiers and mixers. It compares the noise generated by the component to the thermal noise of a 50Ω resistor at room temperature. For example, a noise factor of 2 means the amplifier is as noisy as a 50Ω resistor. In term of math,

$$\begin{aligned} \text{Noise Factor} &= (P_A + P_{50\Omega})/P_{50\Omega} \\ &= 1 + P_A/P_{50\Omega} \end{aligned}$$

where P_A is the noise power due to the amplifier or mixer, $P_{50\Omega}$ is the noise power due to the thermal noise of a 50Ω resistor.

Noise Figure is often given in wireless data sheets. It is noise factor expressed in dB. That is, the noise figure is equal to $10 \cdot \log_{10}(\text{noise factor})$. A typical low noise amplifier (LNA) has a 1dB noise figure, which means the noise due the amplifier is about 26% of the noise due to a 50Ω resistor.

In a typical receiver, the received signal is on the order of -100dBm (2μV), and the thermal noise of a 50Ω resistor in 1MHz bandwidth is about -114dBm. As you can see, the signal-to-noise ratio (SNR) is very low. Noise in the amplifier will further degrade the SNR. Thus, noise figure must keep to a minimum in RF receiver front-ends.

Return Loss is figure-of-merit for signal reflection. Return loss indicates a fraction of the incident power is being reflected back to the source. For example, if you inject 1mW (0dBm) of power into an amplifier and 10% of that power is reflected (bounced) back, the return loss is 10dB. In mathematical terms, return loss is $-10 \cdot \log [(reflected\ power)/(incident\ power)]$. Return loss is often specified both for input and output. Generally it is desirable to minimize the reflected power, thus more power is transferred to the load. Typically, designers aim for at least 10dB return loss. This 10 dB return loss "rule of thumb" is sometimes violated to achieve better noise figure, IP3, or gain in a system.

Oscillator (VCO) Specifications

Phase Noise is a figure-of-merit for oscillator spectral purity. Ideally, an oscillator's output is a single frequency represented by a single vertical line. In reality, there are noises in the oscillator such that the output is not just a single line, but a "skirt" of noises near the carrier (fundamental) frequency. These noises are referred to as phase noise. Phase noise is usually specified as the ratio of noise power in 1Hz bandwidth at an offset frequency away from the carrier to the carrier power. For example, a phase noise specification of -100dBc/Hz at 100kHz offset means the noise power in 1Hz bandwidth at 100kHz away from the carrier is 100dB below the carrier power (Figure 5).

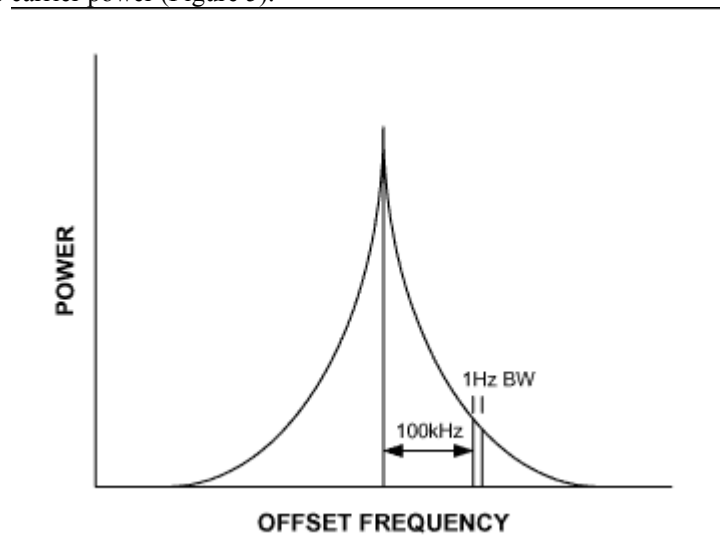

Figure 5. Output spectrum of an oscillator. The skirt is due to the phase noise in the oscillator.

Low phase noise is important in wireless receivers because of reciprocal mixing. As shown in Figure 6, the noisy local oscillator (LO) is mixed with the desired received signal and converted to the IF. If there is an interfering signal present (from another transmitter), it also mixed with the LO and down converted to the IF frequency range. Because the interferer is much stronger than the desired signal, the "tail-end" of the phase noise is spilled into the IF channel. This noise reduces the signal-to-noise ratio and degrades the receiver's performance. A low phase noise LO is important in such receivers with strong interferers.

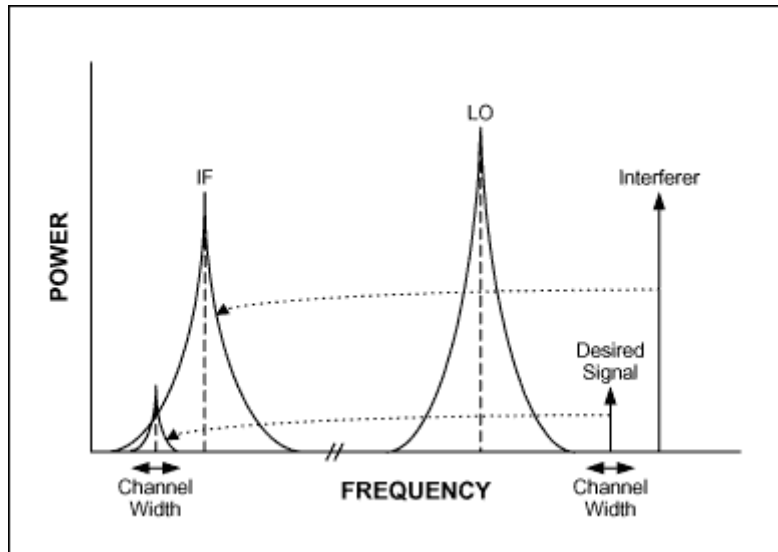

Figure 6. Both the desired and interferer signals are downconverted to the IF. Due to the phase noise of the oscillator, the tail noise of the downconverted interferer is on top of the desired channel and cannot be easily filter out.

Tuning Range is a range of frequencies that the VCO covers. For example, a VCO's nominal frequency is 900MHz, but it can be tuned from 850MHz to 950MHz by varying the tuning voltage at its tuning input. The tuning range is 100MHz. Wide tuning range is often desired to cover the operating frequency range over a specified supply voltage and temperature range.

Tuning Gain or VCO Gain is a measure of how sensitive the VCO is when the tuning input voltage is changed. For example, a tuning gain of 50MHz/V means there will be a 50MHz frequency variation for a 1V tuning voltage changes. Often low tuning gain is desired because it generally produces lower phase noise, due to the varactor being loosely coupled to the tank of the oscillator.